



Wye Delta Reduced Current SERIES MP430 (Open Transition) - MP435 (Closed Transition) Combined Manual and Automatic



Metron Fire Pump Controllers conform to the latest requirements of National Fire Protection Association's Standard for Centrifugal Fire Pumps as adopted by Underwriters Laboratories and Factory Mutual. They are short circuit withstand rated and listed by Underwriters Laboratories and approved by Factory Mutual Research Corporation.

Wye-Delta controllers require six leads from the motor to the controller. These leads are connected by the controller first in the Wye configuration which draws 33% of normal starting current and develops 33% of normal starting torque. After a short time delay, the controller then connects the motor winding in a Delta configuration, applying full voltage, drawing full load running current and developing full running torque.

Sizes range from 15 to 700 horsepower, 200 to 600 volts (480 volts max. when supplied with transfer switch), 50 or 60 Hz. These controllers are for use on reduced voltage type installations.

Only the highest quality components, all UL listed or UL recognized, are used throughout to assure the best possible reliability. The cabinet is fabricated of heavy gauge reinforced steel with drip-proof hood. All field wiring and service connections may be made from the front, allowing the controller to be mounted flush against a wall.

Controllers are completely wired, assembled, and tested at the factory before shipment and ready for immediate installation.





Standard and Optional Features



Standard Features

- » NEMA Type 2 drip proof metal freestanding enclosure
- » Operator Interface Device (OID) with 4 lines by 20 character display with large character backlit Liquid Crystal Display (LCD) capable of being read in both direct sunlight or dark lighting conditions
- » 10 pushbuttons for easy screen navigation, LED lamp test, alarm reset, controller test and horn silencing
- » Removable labels to allow for easy field language changes
- » All controller settings are programmable through the OID. All features are enabled or disabled through the OID, no jumpers or external wires are needed allowing easy field modification
- » The system status data is displayed on the OID. The displayed items include: System pressure, Phase to Phase (AB, BC, AC) voltage, Phase current (A, B, C), Current time and date, System Events and Notifications such as Remote Start, Local Start etc., Number of starts, Total motor run hours, Time remaining on sequential motor start and motor stop timers, Status of automatic stop setting.
- » Auxiliary alarm functions displayed on the OID LCD screen
- » Audible horn with silence feature for silenceable alarms
- » Lamp test feature
- » Foreign languages selectable through the OID
- » Microprocessor based logic with real time/date clock capable of running a minimum of 14 days without AC power connected to controller
- » SD Memory card used to record pressure log, event and log, and auxiliary user programs. Pressure log is stored in separate comma delimited ASCII text files with each file containing data for one day. The SD card is removable and can be read by any PC equipped with an SD card reader.
- » Input and output status LED's provide visual indication of each discrete input's or output's on/off status
- » One RS485 Serial Port
- » MODBUS Communication Protocol via RS485 port
- » Service Entrance Rated

Standard Auxiliary Alarms

The controller includes as standard six (6) discrete auxiliary inputs, nine (9) form 'C' auxiliary relay outputs. These auxiliary inputs and outputs are in addition to those mandated by NFPA 20. All auxiliary inputs, outputs, and OID Display can be field programmed through the OID.

Nine (9) of the following auxiliary alarms can be programmed and recorded in the event/alarm logs and annunciated on the OID display screen and/or output relay contact(s). These alarm conditions include:

- | | |
|----------------------------|-----------------------|
| LOW PUMP ROOM TEMP | LOW PURGE PRESSURE |
| RESERVOIR LOW | LOW GEAR OIL PRESSURE |
| RESERVOIR EMPTY | HIGH GEAR OIL TEMP |
| RESERVOIR HIGH | GAS DETECTION |
| FLOW METER ON | HIGH VIBRATION |
| RELIEF VALVE OPEN | EMERGENCY POWER ON |
| LOW SUCTION PRESSURE | PUMP ROOM DOOR OPEN |
| LOW FIREWATER PRESSURE | |
| HIGH PUMP ROOM TEMPERATURE | |





Standard and Optional Features

Data Logging

The controller includes two (2) separate data logs for storing system data that is readable through the OID or copied to a computer equipped with an SD card reader. The 2 data logs are as follows:

Pressure Log: The pressure log provides a continuous pressure record for 30 days. The pressure log samples shall be time and date stamped and stored in permanent non-volatile SD memory card. The pressure log can be searched by each sample, by minute, or by hour through the OID.

Event Log: The event log will store up to 300 of the most current events. These events can include, but is not limited to, any of the following events/alarms:

- PUMP RUNNING
- POWER AVAILABLE
- PHASE REVERSAL
- MOTOR OVERLOAD
- REMOTE START
- LOCAL START
- PUMP ON DEMAND
- SYSTEM FAULT
- PRESSURE TRANSDUCER FAULT
- PUMP FAILED TO START
- LOW INTAKE SHUTDOWN ALARM
- SUPERVISORY POWER FAILURE
- LOW PRESSURE
- AUTO WEEKLY TEST START
- UNDER FREQUENCY
- OVER FREQUENCY
- LOW ZONE/ HIGH ZONE CONTACTS
- HIGH DISCHARGE PRESSURE
- NO LOAD CONDITION

Model Number Designation

Example: MP435-H-75-480C

MP430 or MP435 -- Model Type

- **X** -- Option Designation(s)
- **XXX** -- Horsepower Rating: 15-700
- **XXX** -- Voltage Rating: 200-600 VAC
- X** -- Withstand Rating: B - 22,000 (@575 VAC) 50,000 (200-480 VAC)
C - 100,000 (200-480 VAC)

Information required with order: 1) Model Type 2) Motor Horsepower 3) Line Voltage, phase and frequency 4) Options, if any (complete description)

Options

Option H: Space Heater

If the ambient atmosphere is especially damp, a space heater rated at 100 watts may be supplied to reduce moisture in the cabinet. A thermostat is supplied as standard with this option. A humidistat may be substituted if specified.

Option W: Omit Legs

For systems where the controller is mounted on a common skid with the pump and motor, the legs of the controller may be omitted, 3" (76.2mm) channels or wall mounting brackets can be supplied. If specified, lifting eyes may also be supplied.

Enclosure

The following NEMA type enclosures are also available: 3R, 4, 4X (Painted Cold Rolled Steel), 4X (304 or 316 Stainless Steel), and 12.

Consult factory for additional options.

Standard Withstand Ratings

VOLTS	HP -- RMS SYMMETRICAL
200-208	15-150 -- 100kA
220-240	15-200 -- 100kA
380-415	15-300 -- 100kA
460-480	15-400 -- 100kA
200-208	200-250 -- 50kA
220-240	250-300 -- 50kA
380-415	350-350 -- 50kA
460-480	500-600 -- 50kA
550-600	15-400 -- 22kA





Specifications

General Controller Description

The Fire Pump Controller shall be factory assembled, wired and tested as a unit and shall conform to all requirements of the latest edition of NFPA 20 and by Third Party Listed by Underwriters Laboratories (UL) and Approved by Factory Mutual (FM). The controller shall be available for 208, 230, 380-415, 480, or 575-600 volt three phase power.

Controller Equipment Features

The controller shall include the following standard features:

- » NEMA Type 2 drip proof metal freestanding enclosure
- » Operator Interface Device (OID) with 4 lines by 20 character display with large character backlit LCD capable of being read in both direct sunlight or dark lighting conditions
- » 10 pushbuttons for easy screen navigation, system test, lamp test, alarm reset, and horn silencing
- » Multicolored LED's for alarm and mode annunciation
- » LEDs shall be labeled with removable labels to allow for easy field modification of language changes
- » All controller settings shall be programmable through the OID and shall be protected by two password levels
- » All features shall be enabled or disabled through the OID, no jumpers or external wires shall be needed or allowed to activate or deactivate a feature
- » The system status data shall be displayed on the OID. The displayed items shall include: System pressure, Phase to Phase (AB, BC, AC) voltage, Phase current (A, B, C), System Events and Notifications, Current time and date, Number of starts, Total motor run hours, Displayed countdown timers for: Sequential motor start and motor stop, Status of Automatic Stop Setting.
- » Audible horn with silence feature for silencable alarms
- » Lamp test feature
- » Foreign languages selectable through the OID
- » One RS485 Serial Port
- » MODBUS Communication Protocol via RS485 port
- » All wiring terminals on PCB's shall be removable type
- » Service Entrance Rated

- » Microprocessor based logic with real time/date clock capable of running a minimum of 14 days without AC power connected to controller and non-volatile flash memory to permanently store the continuous pressure log, event log, alarm log and all user changeable set points and system data. Battery backup of any kind not allowed.
- » Input and output status LED's to provide visual indication of each discrete input's or output's on/off status

Auxiliary Alarms

As standard the controller shall include 6 discrete auxiliary inputs, 9 form 'C' auxiliary relay outputs. These auxiliary inputs and outputs are in addition to those mandated by NFPA 20. All auxiliary inputs, outputs, and OID screens shall be field programmable through the OID. This permits a multitude of customizable controller configurations to meet each installations unique needs without adding cost to the controller. The use of jumpers, soldering, or other external components are not allowed.

The user can select any 9 of the following auxiliary alarms that can be programmed and recorded in the event log and annunciated with an OID screen and output relay contact for conditions such as but not limited to:

- LOW PUMP ROOM TEMP
- RESERVOIR LOW
- RESERVOIR EMPTY
- RESERVOIR HIGH
- FLOW METER ON
- RELIEF VALVE OPEN
- LOW SUCTION PRESSURE
- HIGH PUMP ROOM TEMPERATURE
- LOW FIREWATER PRESSURE
- LOW PURGE PRESSURE
- LOW GEAR OIL PRESSURE
- HIGH GEAR OIL TEMPERATURE
- GAS DETECTION
- HIGH VIBRATION
- EMERGENCY POWER ON
- PUMP ROOM DOOR OPEN

Data Logging

The controller shall have separate data logs for storing system data that is readable through the OID.

Pressure Log: The controller shall have a Pressure log with continuous pressure recording of 30 days of data. The pressure log samples shall be time and date stamped and stored on a removable SD card memory. The pressure log shall be searchable by each sample, by minute, or by hour. Each days entries shall be stored in a separate file on the SD card. SD memory shall be readable by any PC equipped with an SD memory card reader.

Event Log: The event log shall be capable of storing no less than 3000 events. These events shall include, but is not limited to, any of the following events/alarms:

- PUMP RUNNING
- POWER AVAILABLE
- PHASE REVERSAL
- MOTOR OVERLOAD
- REMOTE START
- LOCAL START
- PUMP ON DEMAND
- SYSTEM FAULT
- PRESSURE TRANSDUCER FAULT
- PUMP FAILED TO START
- LOW INTAKE SHUTDOWN ALARM
- SUPERVISORY POWER FAILURE
- LOW PRESSURE
- AUTO WEEKLY TEST START
- UNDER FREQUENCY
- OVER FREQUENCY
- LOW ZONE / HIGH ZONE CONTACTS
- HIGH DISCHARGE PRESSURE
- NO LOAD CONDITION

Each event or alarm recorded in the event log shall have the following data recorded with the event/alarm:

- Time and Date of Event or Alarm
- System Pressure
- Descriptive Text Message of the Event/ Alarm
- Motor Running Status
- Phase to Phase Volts
- Phase Amps

The internal logic of the controller shall be capable of operation in a temperature range of 4.4°C to 50°C and high, non-condensing, humidity levels.

Controllers shall be manufactured by Metron - A Division of Hubbell Industrial Controls, Inc.

www.metroninc.com



Hubbell Industrial Controls, Inc. • 4301 Cheyenne Dr., Archdale, NC 27263
PH: 336-434-2800 • FAX: 336-434-2809 • Email: salesmail@metroninc.com



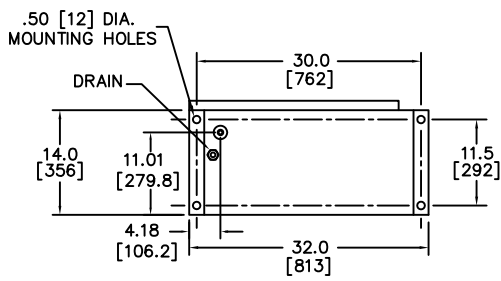
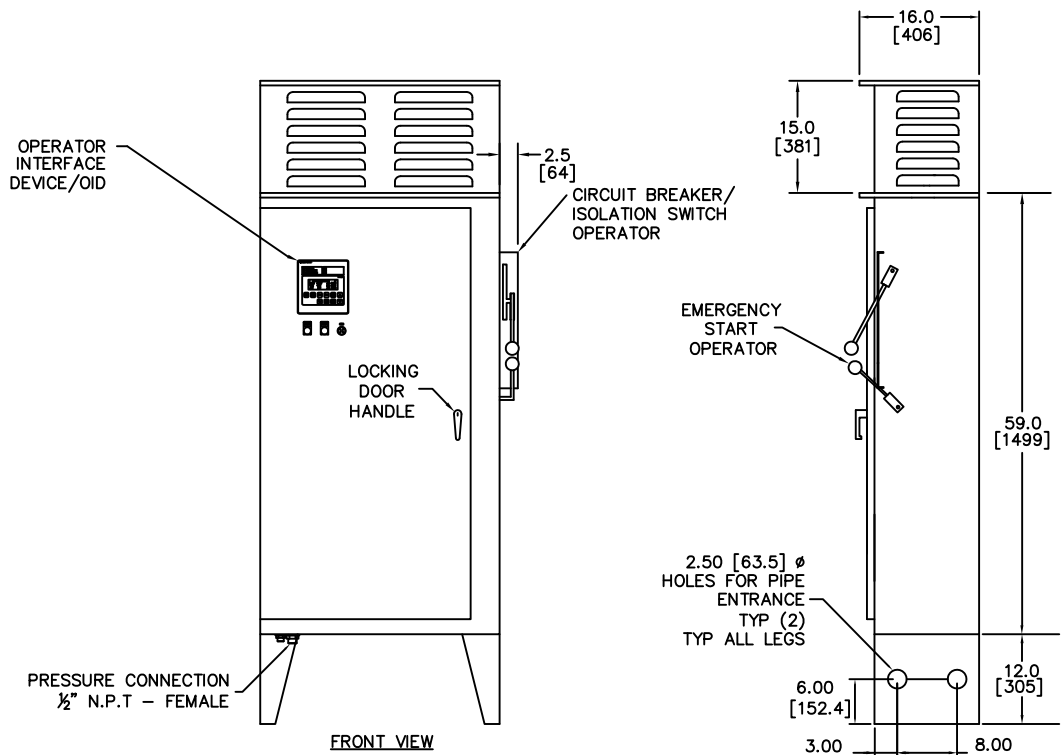

PILOT DEVICE DETAIL

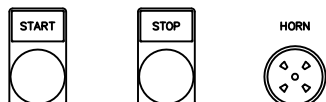
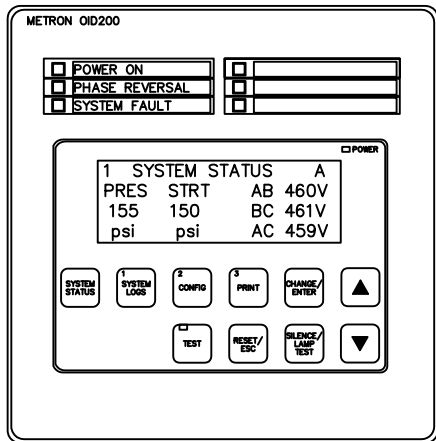

NOTES:
ALL DIMENSIONS IN INCHES AND MILLIMETERS ()
RESISTOR ENCLOSURE RATING TO BE A MAXIMUM TYPE 2.

VOLTAGE	HORSEPOWER
200V	75 HP.
208V	100 HP.
230V	100 HP.
380V, 415V	150 HP.
460V	200 HP.

DRAWN	/K	11-17-04	 METRON A Division of Hubbell ICD, Inc. 4301 Cheyenne Dr., Archdale, NC 27263
CHECK	RA	11-17-04	
APPD	7A.X	11-17-04	
ENCLOSURE DIMENSIONS			OPTIONS:
MODEL MP435			CD33776C
32" CABINET			SCALE N.T.S.
ELECTRIC FIRE PUMP CONTROLLER			SHEET 1 OF 1

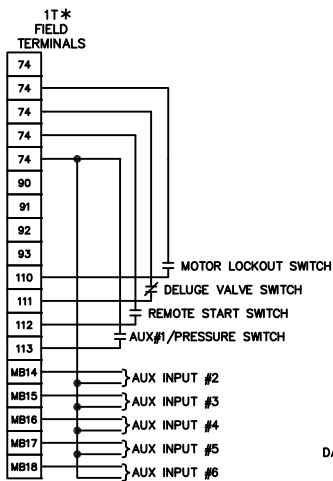

DAUGHTERBOARD TERMINALS

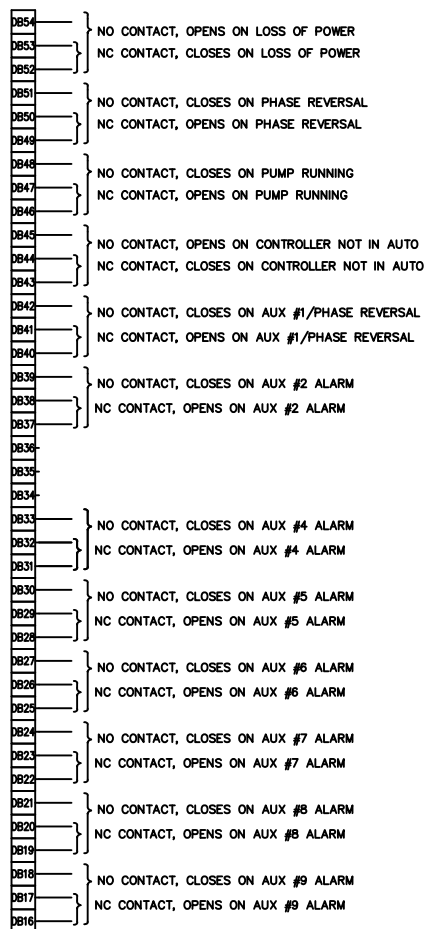

LOCATION OF SIDE MOUNTED RELAY PANEL SEE DETAIL A

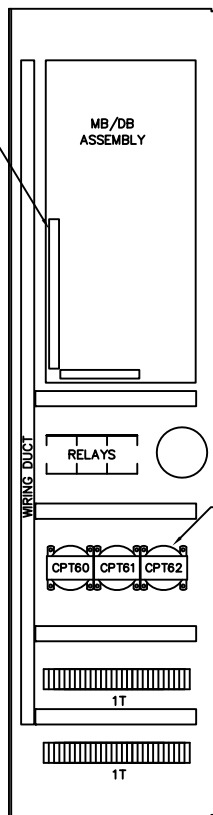

DETAIL A
SIDE MOUNTED
RELAY PANEL

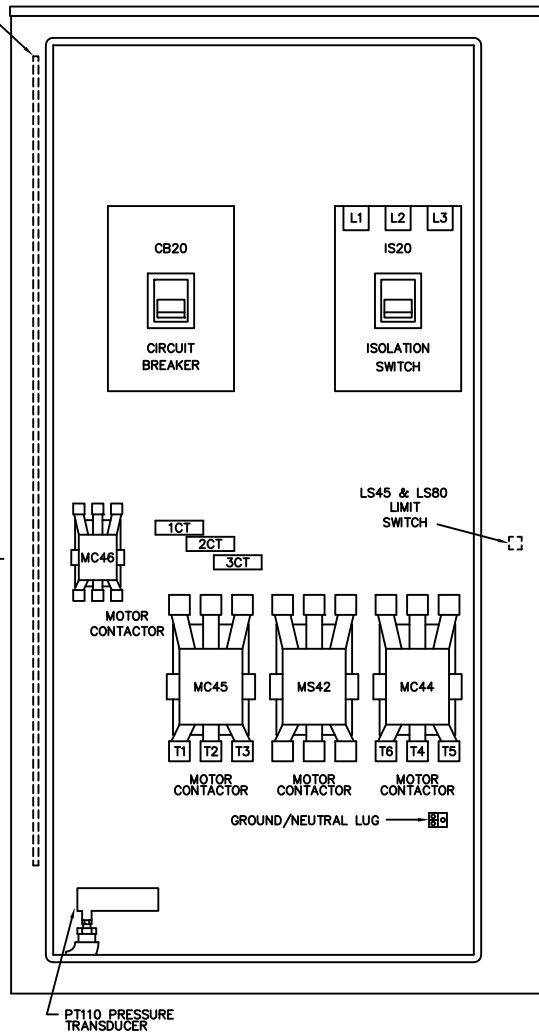

	VOLTS AC					PRIMARY WIRE SIZE	
	200V	208V	220V - 240V	380V - 415V	440V - 480V	LINE TERMINAL WIRE SIZE PER PHASE	SERVICE ENTRANCE GROUND LUG WIRE SIZE
MAXIMUM MOTOR HORSEPOWER	25 HP	25 HP	30 HP	50 HP	60 HP	#14-1/0 AWG	(2) #10-1/0 AWG
	40 HP	40 HP	50 HP	75 HP	100 HP	#4-4/0 AWG	(2) #10-1/0 AWG
	60 HP	75 HP	75 HP	125 HP	150 HP	#4-350 MCM	(2) #10-1/0 AWG
	100 HP	125 HP	125 HP	200 HP	250 HP	(2) #3/0-250 MCM	(2) #10-1/0 AWG
	150 HP	150 HP	200 HP	300 HP	400 HP	(2) #3/0-350 MCM	(2) #6-250 MCM

- NOTES:
1. FIELD TERMINALS ACCEPT COPPER WIRE ONLY. RATED 90°C OR HIGHER
2. FIELD TERMINALS ARE LOCATED AT THE LEFT SIDE AND BOTTOM OF THE DAUGHTER BOARD

DB34 INDICATES DAUGHTERBOARD TERMINAL

DRAWN <i>RA</i>	09-30-04	 METRON A Division of Hubbell ICD, Inc. 4301 Cheyenne Dr., Archdale, NC 27263
CHECK <i>SB</i>	11-05-04	
APPD <i>M.S.</i>	11-05-04	
INTERNAL LAYOUT & EXTERNAL HOOKUP MODEL MP435 ELECTRIC FIRE PUMP CONTROLLER		OPTIONS: CH34277C SCALE SHEET

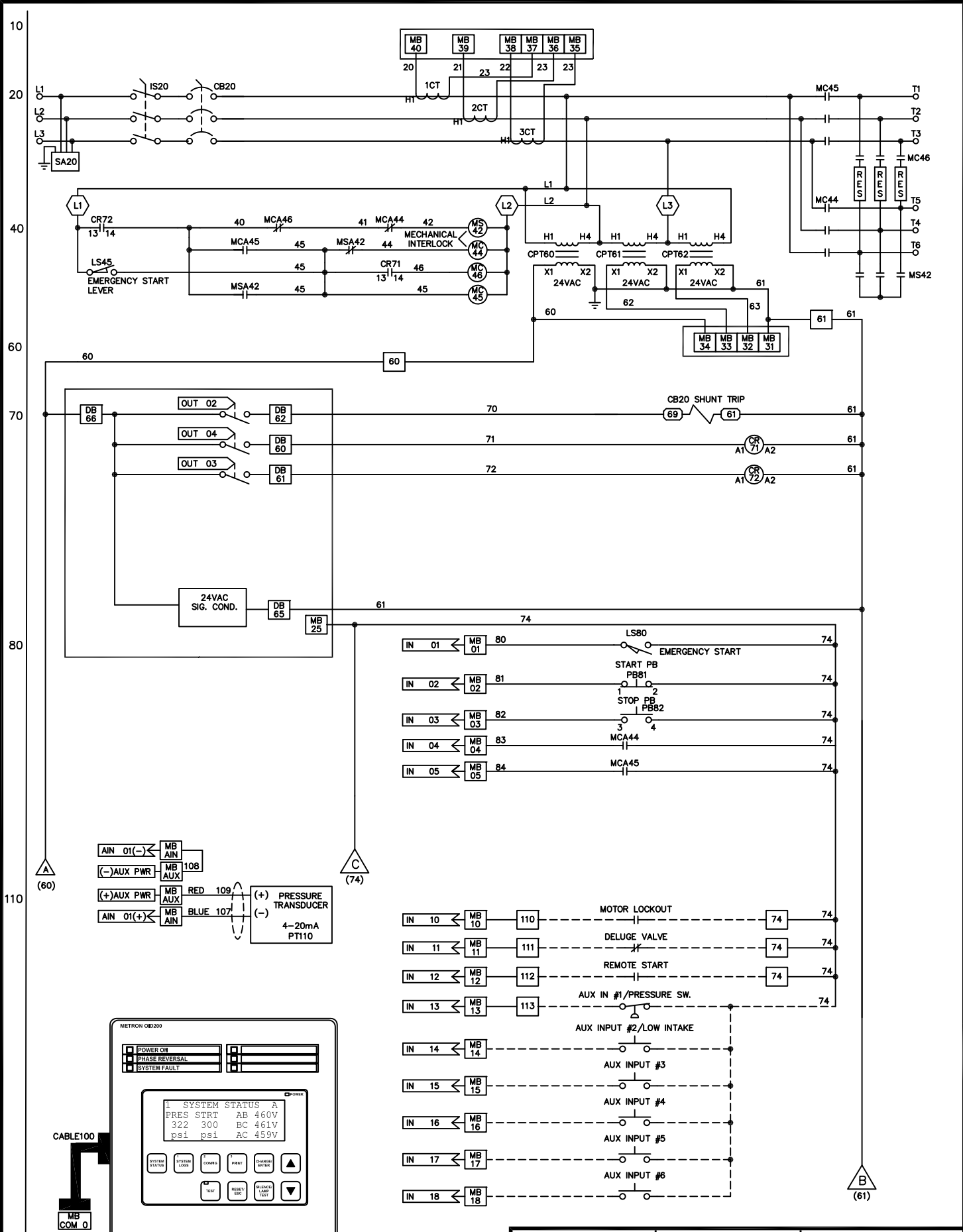

- LEGEND:**
- MB ## - MB = MB100 MOTHERBOARD I/O TERMINAL
 - DB ## - DB = DB200 DAUGHTERBOARD I/O TERMINAL
 - () - WIRES OR TERMINALS LOCATED ON CIRCUIT BREAKER

DRAWN <i>BA</i>	09-30-04	 METRON A Division of Hubbell ICD, Inc. <small>4301 Cheyenne Dr., Archdale, NC 27263</small>
CHECK <i>SB</i>	11-05-04	
APPD <i>M.L.</i>	11-05-04	
SCHMATIC, MODEL MP435 COMBINED MANUAL-AUTOMATIC, WYE-DELTA, CLOSED TRANSITION ELECTRIC FIRE PUMP CONTROLLER		
CS33658D		OPTIONS: SCALE NTS SHEET 1 OF 2

200
230
240
250
260
270

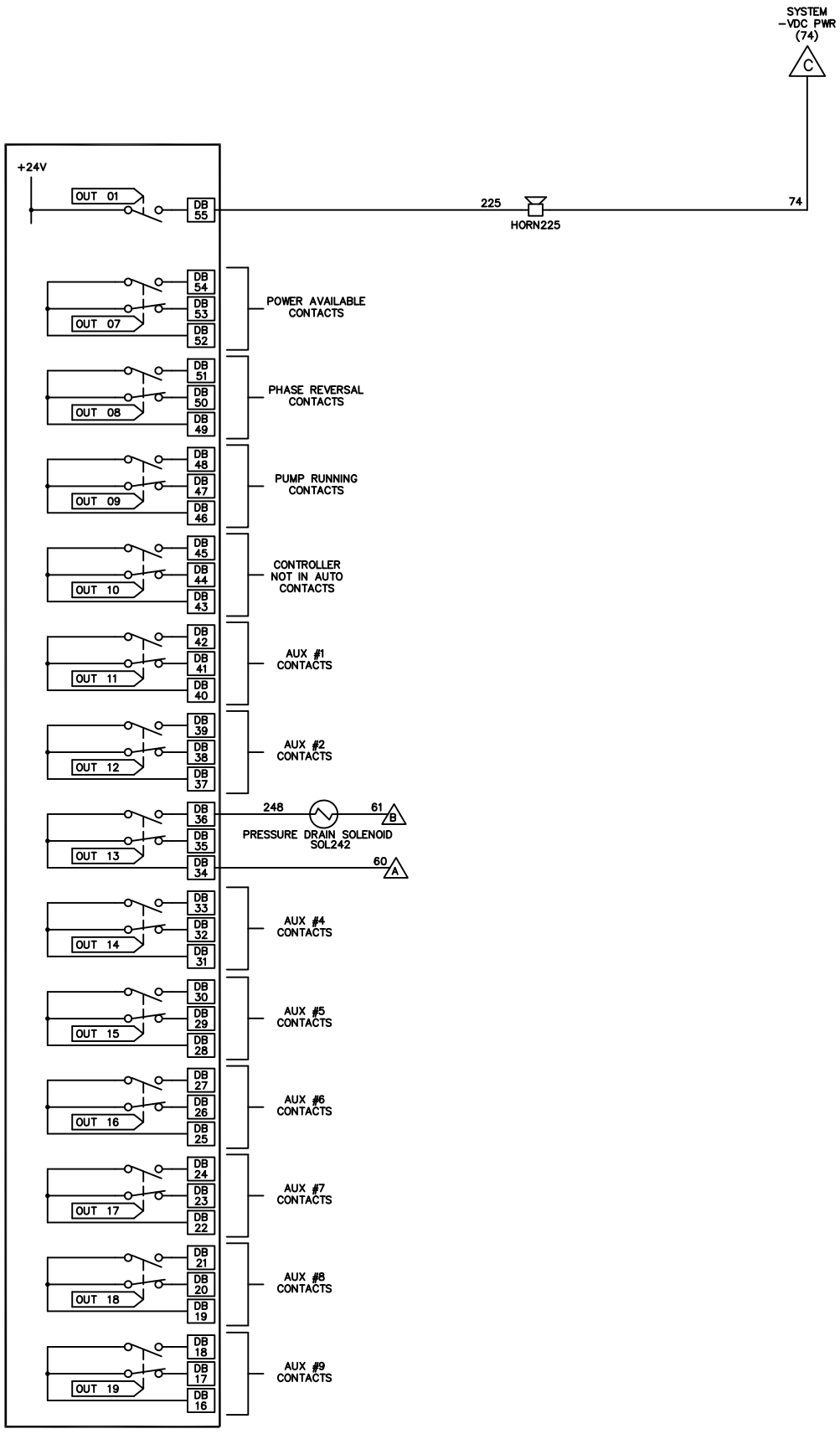

DRAWN <i>RL</i>	09-30-04	 METRON A Division of: Hubbell ICD, Inc. 4301 Cheyenne Dr., Archdale, NC 27263
CHECK <i>SB</i>	11-05-04	
APPD <i>M.G.</i>	11-05-04	
SCHEMATIC, MODEL MP435 COMBINED MANUAL-AUTOMATIC, WYE-DELTA, CLOSED TRANSITION ELECTRIC FIRE PUMP CONTROLLER		OPTIONS: CS33658D
SCALE NTS	SHEET 2 OF 2	

Metron Electric Fire Pump Controller Load Terminal Capacity

MP300, MP400, MP450, MP800

HP	Vts	Terminal Capacity
15-40	200	#8 - 250MCM
15-40	208	
15-50	240	
15-75	380-415	
15-100	480	

HP	Vts	Terminal Capacity
50	200	#6 - 3/0
50	208	
60	240	
100	380-415	
125	480	

HP	Vts	Terminal Capacity
60-75	200	#6 - 300MCM
60-75	208	
75-100	240	
125-200	380-415	
150-200	480	

HP	Vts	Terminal Capacity
100	200	#4 - 500MCM
100	208	
125	240	
250	380-415	
250	480	

HP	Vts	Terminal Capacity
125-150	200	(2) #2 - 600MCM
125-150	208	
150-200	240	
300	380-415	
300-400	480	

HP	Vts	Terminal Capacity
200-250	200	(3) #2 - 600MCM
200-250	208	
250-300	240	
350-400	380-415	
500-600	480	

MP420

HP	Vts	Terminal Capacity
15-60	200	#8 - 250MCM
15-75	208	
15-75	240	
15-125	380-415	
15-150	480	

HP	Vts	Terminal Capacity
75	200	#14 - 2/0
150	380	

HP	Vts	Terminal Capacity
100	200	#6 - 3/0
100	208	
100-125	240	
200	380-415	
200-250	480	

HP	Vts	Terminal Capacity
125-150	200	#6 - 300MCM
125-150	208	
150-200	240	
250-350	380-415	
300-400	480	

HP	Vts	Terminal Capacity
200-250	200	#4 - 500MCM
200-300	208	
250-300	240	
400-500	380-415	
500-600	480	

HP	Vts	Terminal Capacity
300	200	(2) #2 - 600MCM
600	380-415	
700	480	
700	380	

HP	Vts	Terminal Capacity
700	380	(3) #2 - 600MCM

MP430, MP435

HP	Vts	Terminal Capacity
15-60	200	#8 - 250MCM
15-75	208	
15-75	240	
15-125	380-415	
15-150	480	

HP	Vts	Terminal Capacity
75-100	200	#6 - 3/0
100	208	
100	240	
150	380-415	
200	480	

HP	Vts	Terminal Capacity
125-150	200	#6 - 300MCM
125-150	208	
125-200	240	
200-350	380-415	
250-400	480	

HP	Vts	Terminal Capacity
200-250	200	#4 - 500MCM
200-250	208	
250	240	
400	380-415	
500	480	

HP	Vts	Terminal Capacity
300	200	(2) #2 - 600MCM
300	208	
300	240	
500-600	380-415	
600-700	480	

MP700

HP	Vts	Terminal Capacity
15	240	#8 Max
15-25	380-415	
15-30	480	

HP	Vts	Terminal Capacity
15-50	200	#2/0 Max
15-50	208	
20-60	240	
30-100	380-415	
40-125	480	

HP	Vts	Terminal Capacity
60	200	#6 - 250MCM
60	208	
75	240	
150	480	

HP	Vts	Terminal Capacity
75-100	200	#4 - 500MCM
75-100	208	
100	240	
125-250	380-415	
200-250	480	

HP	Vts	Terminal Capacity
125	200	(2) #6-250MCM
125	208	

HP	Vts	Terminal Capacity
125	240	(2) #4-350MCM

HP	Vts	Terminal Capacity
150-200	200	(2) #2-600MCM
150-250	208	
150-300	240	
300-400	380-415	
300-600	480	